

Vintage Airstream TODAY

The Official Newsletter of the Vintage Airstream Club
September/October 2019



VAC officers for 2019

President - Rachel Payne
1st VP - Edward Valentin
2nd VP - Lisa Sly
3rd VP - Lynn Talsma
Recording Secretary -
Joel Ware
Treasurer - Shirley Bolinger
Past Pres. - Dave Morrison

www.vintageairstream.com

The VAC is looking for a new Quarter Master. This person is in charge of housing and sending out current merchandise for the VAC. If you feel qualified please contact VAC President Rachel Payne

Information about the Rendezvous and International Rally will be coming soon. Good things in the works for the Vintage Airstream Club.

Newsletter Editors:
Joyce and Lee Cantrell
Email us newsletter items at:
cantrellnewslettervac@gmail.com

Hello everyone! I'm Rachel Payne, and I'm your new President for the VAC. I have been a VAC member for five years, and I have owned two Airstreams in my life. My first one was a 1958 Overlander 26' single axle. It was a mess so I decided to sell it. My current Airstream is a 1962 Tradewind 24' single axle. Her name is Agnes after my Grandmother on my dad's side. Anyway that's a whole story in itself.

I would like to thank Dave Morrison for his job as the President and helping with getting the tent, going to the meetings, and taking care of things at International. You did a good job, and I thank you for that. Also I would like to thank my fellow officers for helping with the Rendezvous at Pawatan this year. Ten rigs were there, and we had a great time. Also we had a nice turnout for the VAC parade, and all of those that participated were able to have an easy check in at the bull pen. Fifteen rigs participated in the Parade. Fifty or so Airstreams participated in Open House which was a nice turnout. Twenty or so trailers participated in the Concourse de Elegance. I would like to thank everyone who attended the International Rally, and it was great hanging out with you all. We also had happy hour, movie nights and an extra special night for Pee Wee. I want to thank him for installing me and my fellow officers this year--what an honor! Something new this year was Yoga, and I hope we get to do this next year too. We did have our coffee every morning which was enjoyed by most of the VAC members in attendance. We were also on the grounds where Secretariat was born and raced during the first three years of his life. We did show the movie one night, and it was our biggest turnout!

As your President I will do my best to help the VAC grow, have fun, and let people know that our club exists.

On a side note we are looking for a Quartermaster who handles the club merchandise. If you are looking for a position in the VAC, this position might be for you. Please email me for more info. Currently I have the merchandise with me. Thank you, Christine, for all the years you served as our Quartermaster. Don't forget to renew your membership it's due by December 31, 2019.

Sincerely

Rachel Payne



2019 Vintage Airstream Concours d'Elegance Winners

Many VAC members cannot attend the WBCCI International Rally and the VAC club events. Following at this year's winners for the various classes. There are many impressive winners. I have included exterior photos with a few interior views of each winner.

Photos submitted by owners of Concours winners



Best In Show

1947 Curtis Wright Clipper
Tilghman, Perry & Linda
Region 06 , Unit 158



Platinum Award

1976 Argosy
Wilson, Robert & Jan
Region 03 , Unit 022





Best Engineered Feature & Silver Award

AC Unit – 1966 Tradewind
Spahr, Bruce & Joy
Region 02 , Unit 170



Best Bambi

1963 Bambi II
Gieniewski, Robin
Region 03 , Unit 161



Gold Award

1964 Safari
Ingersoll, Jeff & Parker
Region 12 , Unit 013



Platinum Award

1962 Ambassador
Lyrek, Chris & Ron
Region 7, Unit 055



Gold Award

1956 Safari
Radford, Bruce & Kelly
Region 03, Unit 161



Gold Award

1964 Overlander
Talsma, Lynn & Gary
Region 3, Unit 032



Gold Award

1956 Safari
Sly, Rod & Lisa
Region 11 , Unit 069



Silver Award

1966 Overlander
Jill and Andy Reyes
Region 2, Unit 053



It appears that VAC members are trying new and different styles for organizing rallies other than the traditional one we know of that stays in one location. Recently two innovative rallies were held. One was organized by Paul and Nanci Drag called the Jackrabbit Sprinter held in early August to the Fiddlers Picnic in Montana. That story is below.

The other innovative rally was organized by Joyce and Lee Cantrell called the Rolling Rally to the North Shore of Minnesota. It was held during the latter part of August and first part of September. This rally story will be in the next issue of our VAC Newsletter.

Starting on an eight day journey to the Fiddlers Picnic and hoping to pick up additional Airstreamers along the way. Paul & Nanci Drag, John Leggett, and Dennis & Sandy Weber (towing with their

1947 Ford woodie) left from Mount Shasta California at the headwaters of the Sacramento River, all Pulling Vintage Airstream trailers.

Our adventures started with a [20 mile gravel road](#) straight to Lava Beds National Monument. The intrepid travelers gave a local car wash a lot of business en route to Boise. We followed along the spectacular Salmon River arriving into Montana and met up with Dal Smilie and the vintage trailer gang where there were a lot of Airstreams, and a wonderful venue at the Mercier family farm along the banks of the Yellowstone River in Livingston. Meeting a wide variety of talented musicians, we camped in a freshly harvested hay field. The fast moving Montana weather made things pretty exciting but pounding rain and a little 40+ mph breeze didn't stop the fun.

For 3 days the Celebration of music, Bluegrass, old Timey, country, cowboy and even some boogie-woogie piano continued, in multiple jam sessions throughout the property.

In conclusion we found the Jackrabbit Sprinter Meet Up "along the way" concept a great option for traveling with a group. Photos will be in the next issue of the newsletter.

Article submitted by Dal Smilie and Nanci Stalzman





The following article was submitted by Jim Cooper. Over the years I have read on the Airstream forum posts about how to check the wiring on a trailer. Jim has a great suggestion about what should be included in every Airstreamer's tool box of things to carry or at least have at home to check if things are or aren't working on their trailers. I'll need to make an RV 7-Wire Tester myself, thanks, Jim!

RV 7-Wire Tester

We are working to make our 67 Globe Trotter the most dependable camping trailer that it can be. Solar, gray tanks, and an under body spare tire holder have been added. The plumbing, electrical, and propane systems have been rebuilt. Now we added a troubleshooting and safety accessory that will work with any trailer – a 7-wire tester. With it you can test turn signals, lights, and leave the lights flashing if needed. Here's how to do it:

Start with 2 inch PVC and a knock-out end cap. You will then need a female 7-wire receptacle, same as tow vehicle, electronic flasher, two single-pole-double-throw-center-off switches, an LED, and 2.2K resistor. Wiring diagram is shown on page 8. Leave enough wire length to pull the end cap out one end of the PVC tube, or the 7-wire and flasher out the other. Flat head screws on both ends hold it together.

Using an electronic flasher will allow the tester to be used with LED lights, incandescent, or a combination. The old thermo-mechanical flashers won't work with LED lights, which don't draw enough current to operate the flasher. I removed the spring loaded cap from the receptacle to make it easier to use. The LED and resistor are added to assure that there is a 12 vdc and common connection to the battery of the trailer. Your tow vehicle charges the battery through this connection, and the battery voltage is used to test or operate the lights with the tester. The receptacle will come with documentation to show wire locations, and small gauge (24) wire is adequate.

Stow this accessory in your truck or trailer, and if all goes well you will never use it. If things are not working, you will be able to determine if it is the truck or trailer. If you want to find your trailer at night or show off, turn the lights on, and if you have to leave the trailer off the road side, turn the flasher on. Photos of the 7-Wire Tester are on page 8.

Continued from page 7

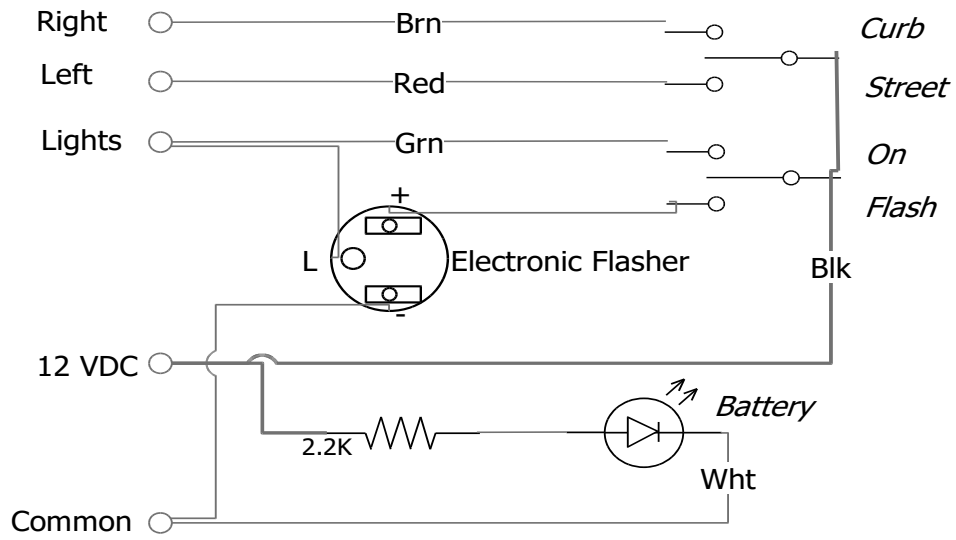

TESTER WIRING DIAGRAM

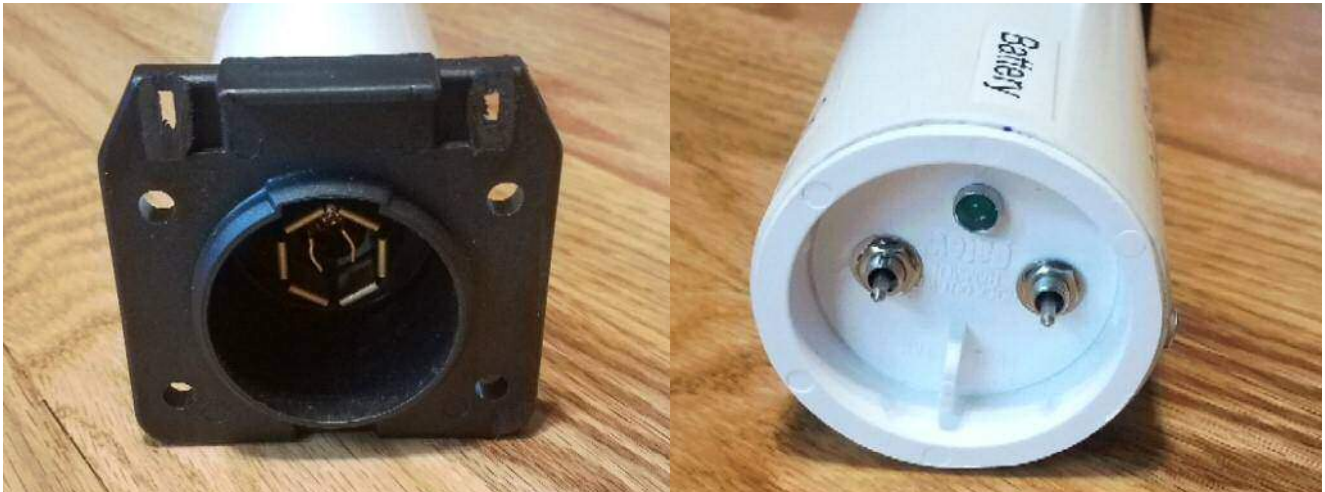

COMPLETED 7 WIRE TESTER

